

KEF CONSTRUCTOR SERIES MODEL CS1A

*Enclosure 12mm birch
plywood, glue & screw
Vol. approx. 8 litres*

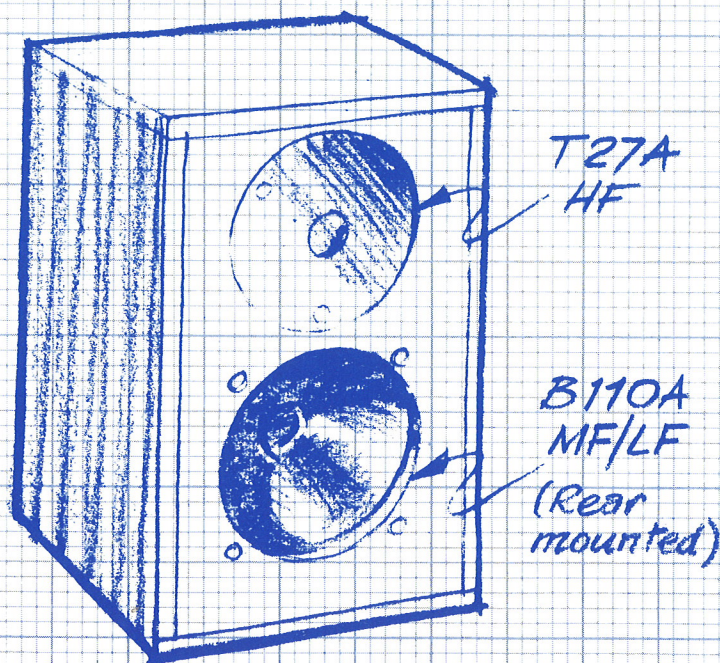

This miniature bookshelf system is based on the famous BBC monitoring loudspeaker type LS3/5A which is used in outside broadcast applications and other situations where space is at a premium and very high peak sound levels are not required. The system employs the same KEF drive units originally specified for the LS3/5A with a somewhat simplified dividing network giving a similar overall frequency response characteristic. Because of the low sensitivity which is inherent in a wide band loudspeaker of diminutive proportions, amplifiers having a power output of 50 watts per channel are recommended for use with this design.

This leaflet gives all the information required to construct the enclosure and dividing network together with curves of terminal voltages which may be useful in checking the operating characteristics of the network. Performance data for the complete loudspeaker are given on the back page. A leaflet giving general information about loudspeaker cabinet construction is also available on request - KEF part No. SL358EN01.

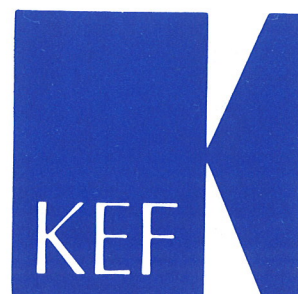

CABINET CONSTRUCTION

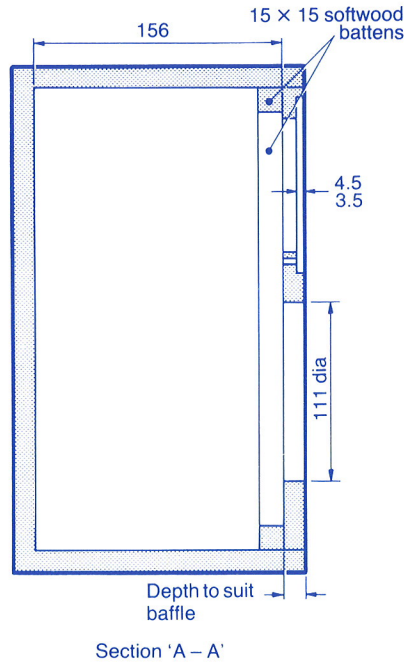
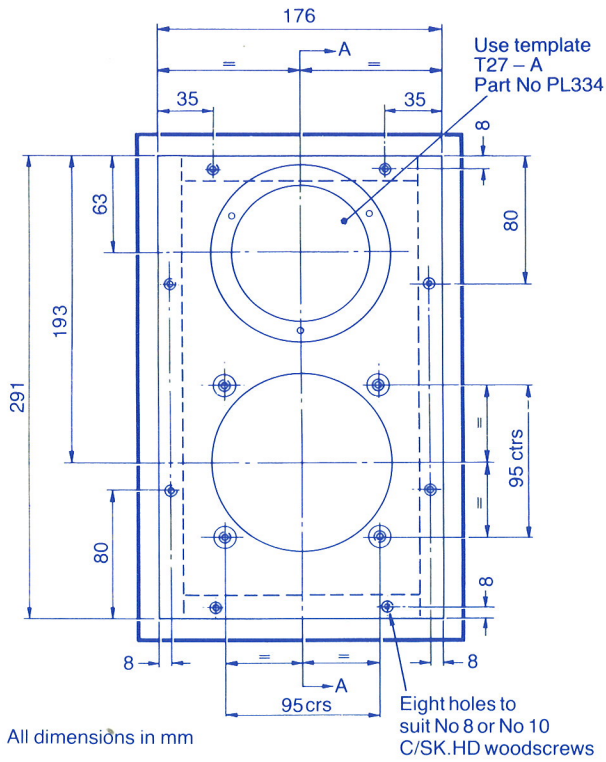

The B110A is mounted behind the baffle. Therefore the back panel must be removable.

The enclosure is constructed from plywood 12mm thick. The method of construction is not critical so long as all joints are generously glued and the enclosure generally rendered airtight. The use of glue blocks along inside edges will provide extra security. The inside surfaces of each side, top and back panel should be laminated with sound deadening material such as "Dedshete", well bonded with a rubber-based adhesive. The damping laminate need not extend to the panel edges but it should cover at least half the inside surface area. See leaflet no. SL358 for general hints on loudspeaker construction.

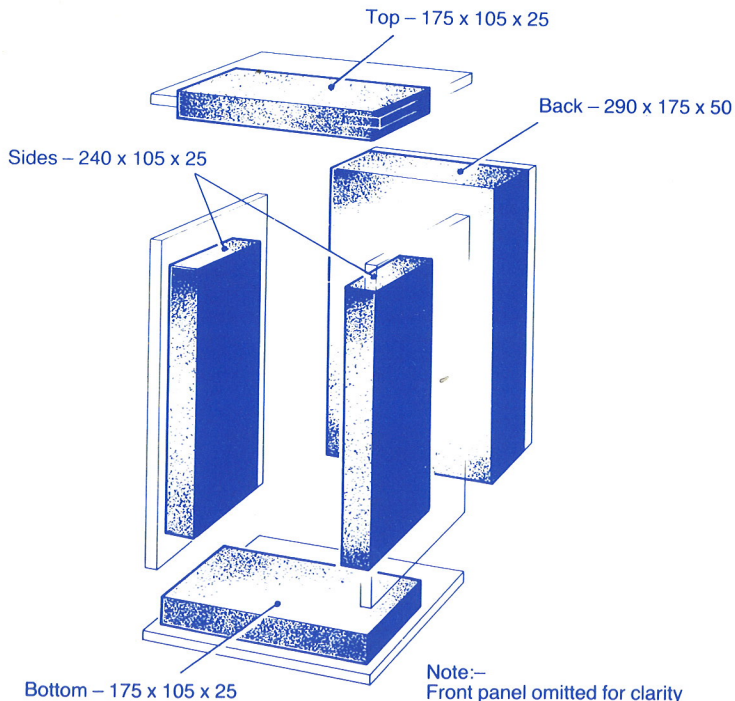

Pads of sound absorbing material are placed inside the cabinet to inhibit the formation of standing waves in the enclosed air space. Suitable materials include polyester foam, resin-bonded fibre glass and acetate fibre. The pads are retained by adhesive or string lacing.

DIVIDING NETWORK

Circuit diagram

This network has been computer designed for use with the specified drive units and enclosure. It may not be suitable for use with other combinations.

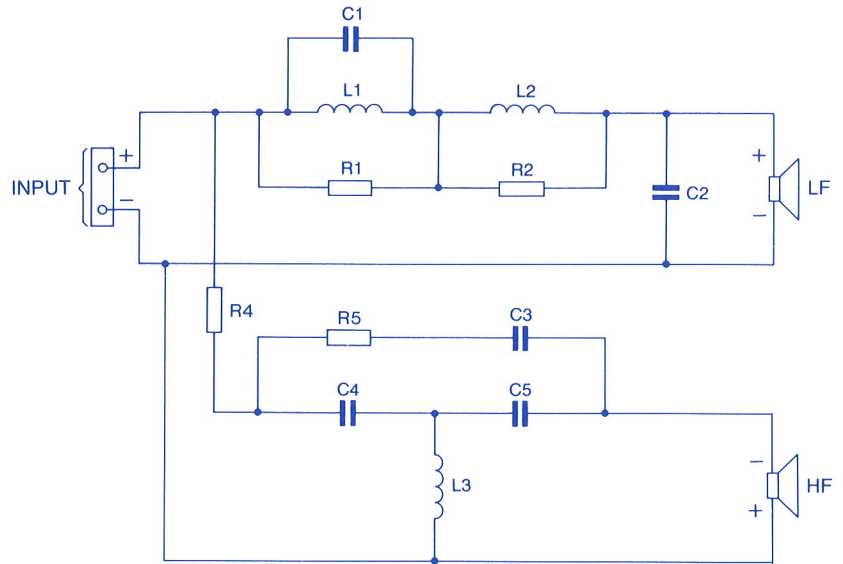

Component list

Components should be chosen with values as close as possible to those shown in the table. Minimum working voltages for capacitors are specified but no harm will be done if higher ratings are used.

| Component | Value | Tolerance | Losses | Notes |
|-----------|--------|-----------|--------------------|--------------------------------------|
| L1 | 0.85mH | ±5% | $R \leq 0.3\Omega$ | ≥100V DC working rev electrolytic |
| L2 | 3.1mH | ±5% | $R \leq 0.6\Omega$ | |
| L3 | 0.18mH | ±5% | $R \leq 0.2\Omega$ | |
| C1 | 25μF | ±10% | $d \leq 0.08$ | |
| C2 | 5μF | ±10% | $d \leq 0.04$ | |
| C3 | 0.33μF | ±10% | $d \leq 0.01$ | ≥50V DC working polyester |
| C4 | 3.3μF | ±10% | $d \leq 0.04$ | |
| C5 | 7μF | ±10% | $d \leq 0.04$ | ≥50V DC working rev electrolytic |
| R1 | 47Ω | ±5% | | 6W |
| R2 | 150Ω | ±5% | | 6W |
| R4 | 3Ω | ±5% | | 6W |
| R5 | 220Ω | ±5% | | 2W |

d is loss factor of capacitor. It is related to series resistance by the formula $R = \frac{d}{2\pi f C}$
 above d values are measured at 1kHz
 R3 = Wire link

Testing the network

Operation of the dividing network can be checked by substituting resistive loads of 8 ohms value in place of the loud - speakers. With a constant voltage input of varying frequency derived from a signal generator or test disc terminal volts at the output of each filter section should accord with the curves opposite.

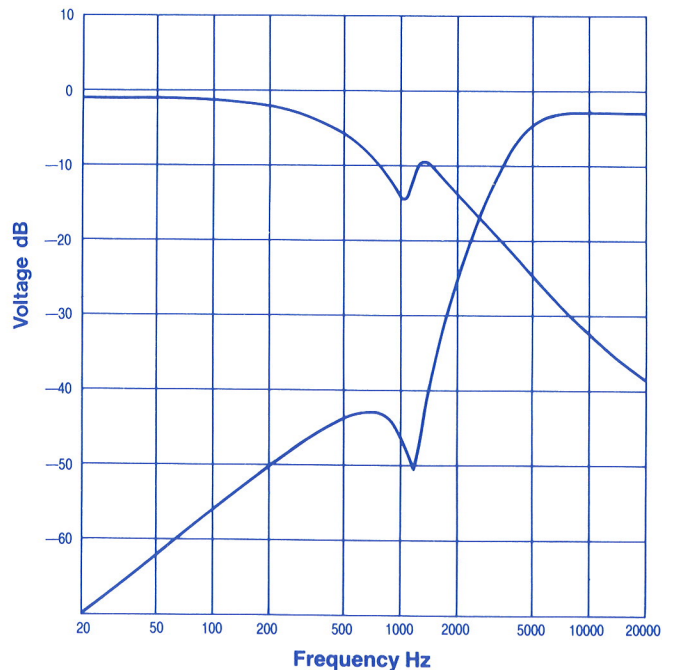

KEF CONSTRUCTOR SERIES MODEL CS1A

Technical Specification

| | |
|----------------------------------|--|
| Frequency range | 85Hz – 30kHz \pm 3dB at 2m on reference axis |
| Maximum output | 98dB spl on programme peaks under typical listening conditions |
| Characteristic sensitivity level | 81dB spl at 1m on reference axis for pink noise input of 1W |
| Enclosure type | Closed box |
| System resonance frequency | 70 Hz |
| Internal volume | 8 litres |
| Nominal impedance | 8 ohms |
| Programme rating | 50W |
| Minimum amplifier requirements | 20W |
| Internal dimensions | 291 \times 176 \times 156mm |
| External dimensions | 315 \times 200 \times 180mm |
| Material | 12mm plywood |
| Drive units | LF: B110A SP1003 HF: T27A SP1032 |

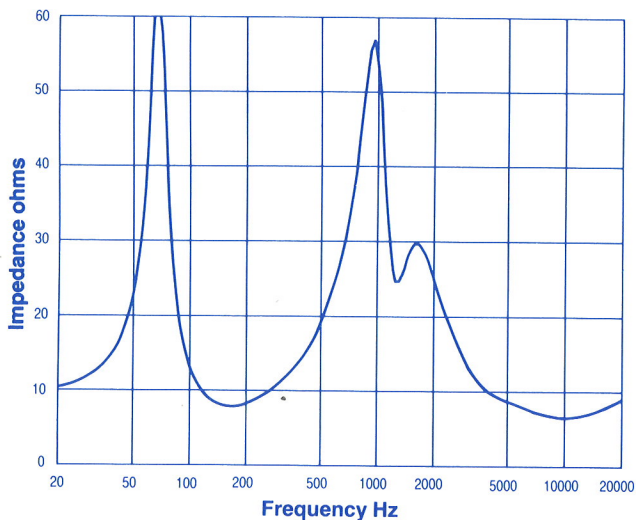

Impedance Characteristic

The modulus of impedance curve provides a useful method of checking for suspected faults. The above curve is measured under constant current conditions at 100 mA.

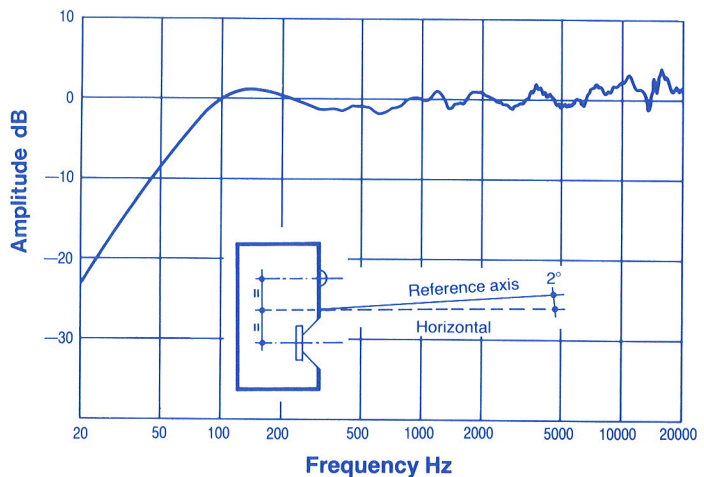

Amplitude-Frequency Response

The completed loudspeaker will produce the above amplitude-frequency response when measured in free field conditions at a distance of 2m on the reference axis.



KEF products are manufactured in England and distributed in the United Kingdom by:
KEF Electronics Ltd
Tovil
Maidstone
Kent ME15 6QP England
Telephone: 0622 672261
Telex: 96140

Distribution in the USA by:
Intratec
PO Box 17414
Dulles International Airport
Washington, DC 20041 USA
Telephone: (703) 435 9100

KEF reserve the right to incorporate developments and amend the specifications without prior notice, in line with continuous research and development.